

## QSLH high pressure filter

Home >> Products >> Air treatment units >> High pressure series >> QSLH high pressure filter:



### Product description:

It is a very simple high pressure filter ----- one of air treatment units, which is used a lot for high pressure equipments. The filtration is 25~50 μ .

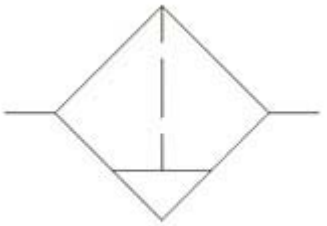
Ordering Code	Graphic symbol
<p>QSLH</p> <p> </p> <p>High Pressure Filter</p> <p>-15</p> <p> </p> <p>Joint Pipe Bore</p> <p>08:G1/4"</p> <p>10:G3/8"</p> <p>15:G1/2"</p> <p>20:G3/4"</p> <p>25:G1"</p>	
Overall Dimension	

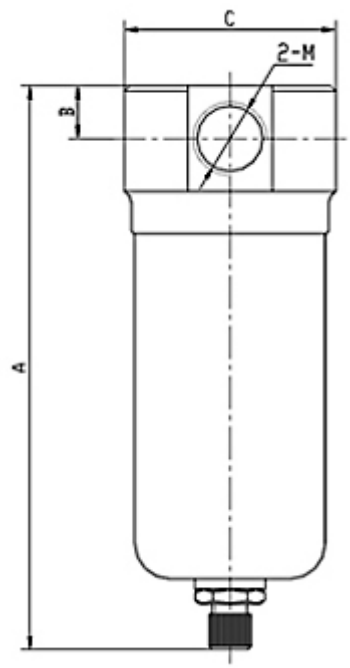

### Specification

Code	A	B	C	M	
Bore					
10	160	15	60	G3/8	
15	160	15	60	G1/2	
20	215	75	90	G3/4	
25	215	75	90	G1	
Specification					
Model	QSLH-08	QSLH-10	QSLH-15	QSLH-20	QSLH-25
Operating Fluid	Air				
Joint Pipe Bore	G1/4	G3/8	G1/2	G3/4	G1
Filtering Element Roughness	25-50µ				
Water Segregation Efficiency	≥80%				
Max. Working Pressure	4MPa				
Operating Temperature Range	5-80℃				
Model	LQR-08	LQR-10			
Operating Fluid	Air				
Joint Pipe Bore	G1/8	G1/4			
Filtering Element Roughness	40µ				
Range of Adjustable Pressure	0.05-0.08MPa				
Max. Adjustable Pressure	0.95MPa				
Ensured Pressure Resistance	1.5MPa				
Operating Temperature Range	5-60℃				

## Company Information:

### Company Name:

Ningbo Lida Pneumatic Kit Co.,Ltd.

**Website:**<http://www.nblida.cn>

### Address:

Eighth Quarter, Zhongxing East Road, Xikou, Fenghua, Zhejiang, China.

**Post-code:**315500

**Contact Person:**Joy Qian exporting manager

### Phone:

**Telephone:**0086-574-88846388

**Fax:**0086-574-88846288

**Email:** export@nblida.cn