

LQR plate type regulator

Home >> Products >> Air treatment units >> High pressure series >> LQR plate type regulator



Product description:

We design and manufacture air treatment units product ----- this high pressure regulator by ourself. It can be installed directly on your equipment ,without any connectors(fittings and air pipe). The adjustable pressure range is: 0.05~0.8Mpa.

Ordering Code

Graphic symbol

LQR	-	08
Plate Type Regulator		Joint Pipe Bore
		08:G1/8"
		10:G1/4"

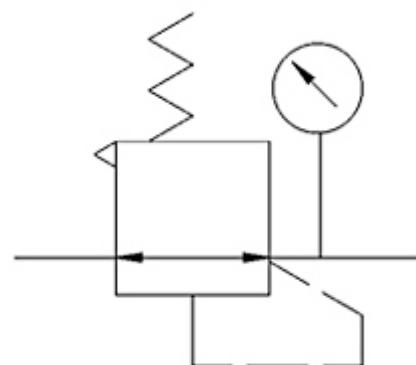

Specification

Model	LQR-08	LQR-10
Operating Fluid	Air	
Joint Pipe Bore	G1/8	G1/4
Filtering Element Roughness	40 μ	
Range of Adjustable Pressure	0.05-0.08MPa	
Max. Adjustable Pressure	0.95MPa	
Ensured Pressure Resistance	1.5MPa	
Operating Temperature Range	5-60°C	

Overall Dimension

TYPE:LQR

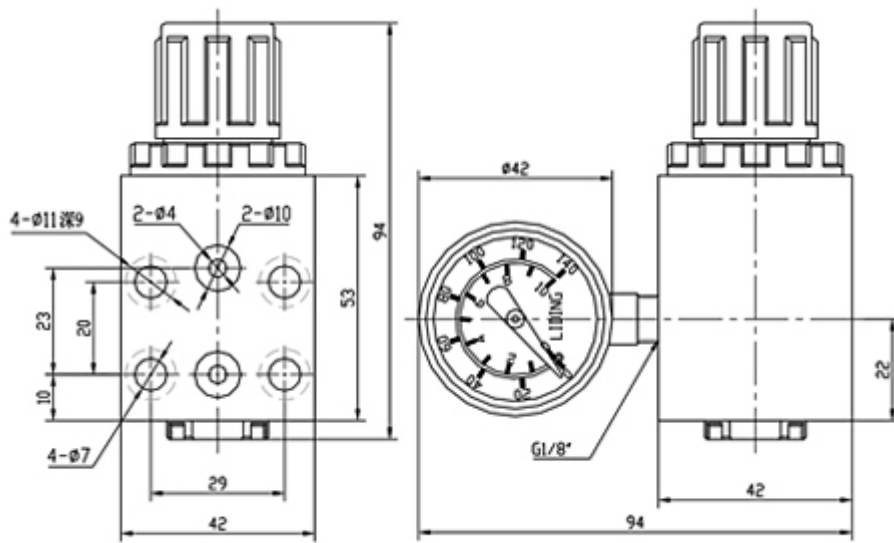

Pressure Character

Flowing Character

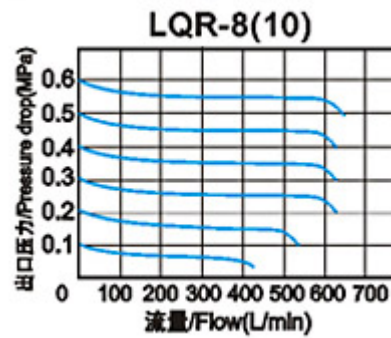
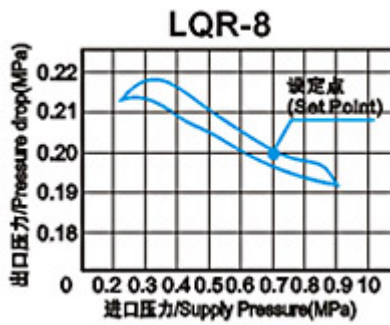

Company Information:

Company Name:

Ningbo Lida Pneumatic Kit Co.,Ltd.

Website:<http://www.nblida.cn>

Address:

Eighth Quarter, Zhongxing East Road, Xikou, Fenghua, Zhejiang, China.

Post-code:315500

Contact Person:Joy Qian exporting manager

Phone:

Telephone:0086-574-88846388

Fax:0086-574-88846288

Email: export@nblida.cn