

LQ110 group valve

Home >> Products >> Directional control valve >> Other solenoid valve >> LQ110 group valve:



Product description:

Directional control valve product ----- LQ110 mini solenoid valve is specially for textile and electronical equipments. It is very compact and easy installation. It can work high frequency with very steady performance. The connector size is M5. Working pressure 0.15~0.8Mpa.

Ordering Code

LQ	110	- □F	C
Company Code	Series NO	Joint Base Number	出气形式
	100:100 Series	100:1~10Joint	C:侧部出气
	200:200 Series		D:底部出气

Specification

Model	LQ110-□FX
Working Medium	经 40 微米过滤的空气/40 Micron Filtered Air
The Position Counting	二位三通/Two-position Three-way
Joint Pipe Bore	M5
Operating Temperature	0~60℃
Working Pressure	0.15~0.8Mpa
Max. Pressure Resistance	1.2Mpa
Operating Voltage	AC220v&DC24v
Voltage Range	±15%
Max.testing Voltage	1500V
Protection Class	IP65(DIN40050)
Insulation	F 级
Highest Action Frequency	每秒 5 次/5 Cycle/Sec
Use Life	5Million Times

Overall Dimension

TYPE: 二边安装
Fix on Two Sides

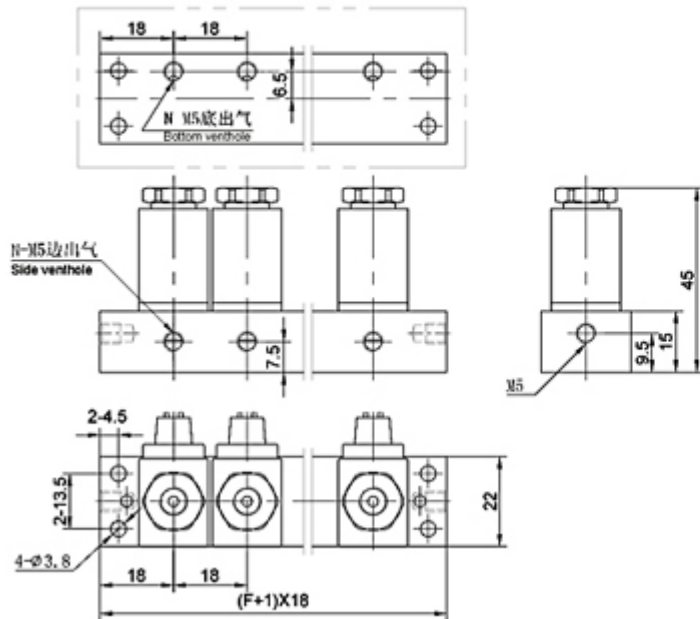

TYPE: 底部安装
Fix on Base

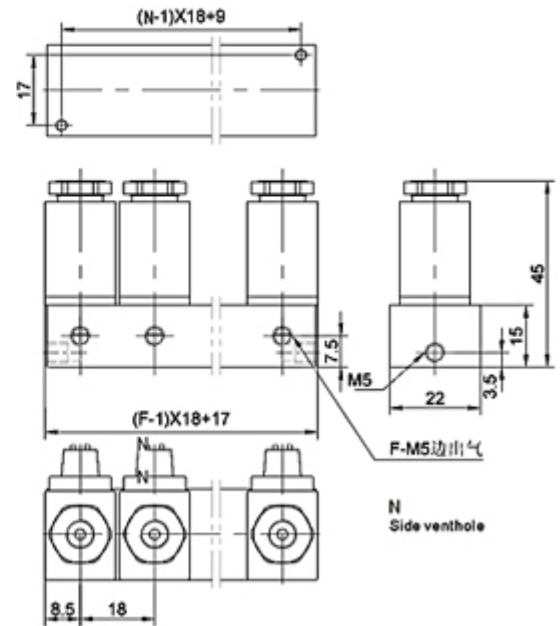

Company Information:

Company Name:

Ningbo Lida Pneumatic Kit Co.,Ltd.

Website:<http://www.cn-lida.com>

Address:

Eighth Quarter, Zhongxing East Road, Xikou, Fenghua, Zhejiang, China.

Post-code:315500

Contact Person:Lacey Liu exporting manager

Phone:

Telephone:0086-574-88846388

Fax:0086-574-88846288

Email:export@nblida.cn